

# ± 20A Integrated Current Sensor

## FEATURES

- Integral Non-inductive Current Sense Element with Internal Kelvin Connections
- 20A Current Rating
- Bi-directional, High Side or Low Side Sensing
- Internal Temperature Nulling Circuitry for Current Sense Element and Amplifier
- Logic Compatible Current Direction Status Output
- Low Offset, Chopper Stabilized Current Sense Amplifier
- Uncommitted Amplifier with User Programmable Gain
- Overcurrent Indication with User Programmable Threshold

## DESCRIPTION

The UCC3926 Current Sensor IC contains a wideband, transimpedance amplifier for converting the current through an internal, non-inductive 1.3mΩ shunt resistor into a proportional voltage. The sense element operates in both high-side (VDD referenced) and low-side (GND referenced) applications.

The UCC3926 can measure currents up to ± 20A. This transimpedance amplifier gain is precisely trimmed to 33.3mΩ to convert a 15A input into a 500mV output signal. It has a very low input offset voltage from chopper-stabilization. A cross-switching block rectifies the input signal by forcing the differential output, AOP positive with respect to the other differential output, AON. SIGN indicates the polarity of the current.

The UCC3926 programmable amplifier provides three functions. It converts the differential transimpedance output signal into a single-ended signal. It has a user-controlled gain stage that sets the maximum current level to the desired voltage and it level shifts the zero current point to the desired level as well. A comparator then compares the output of the instrumentation amplifier to a user-set reference voltage on OCREF, which provides an over-current status bit OC.

The UCC3926 is available in the 16 pin SOIC package.

## BLOCK DIAGRAM

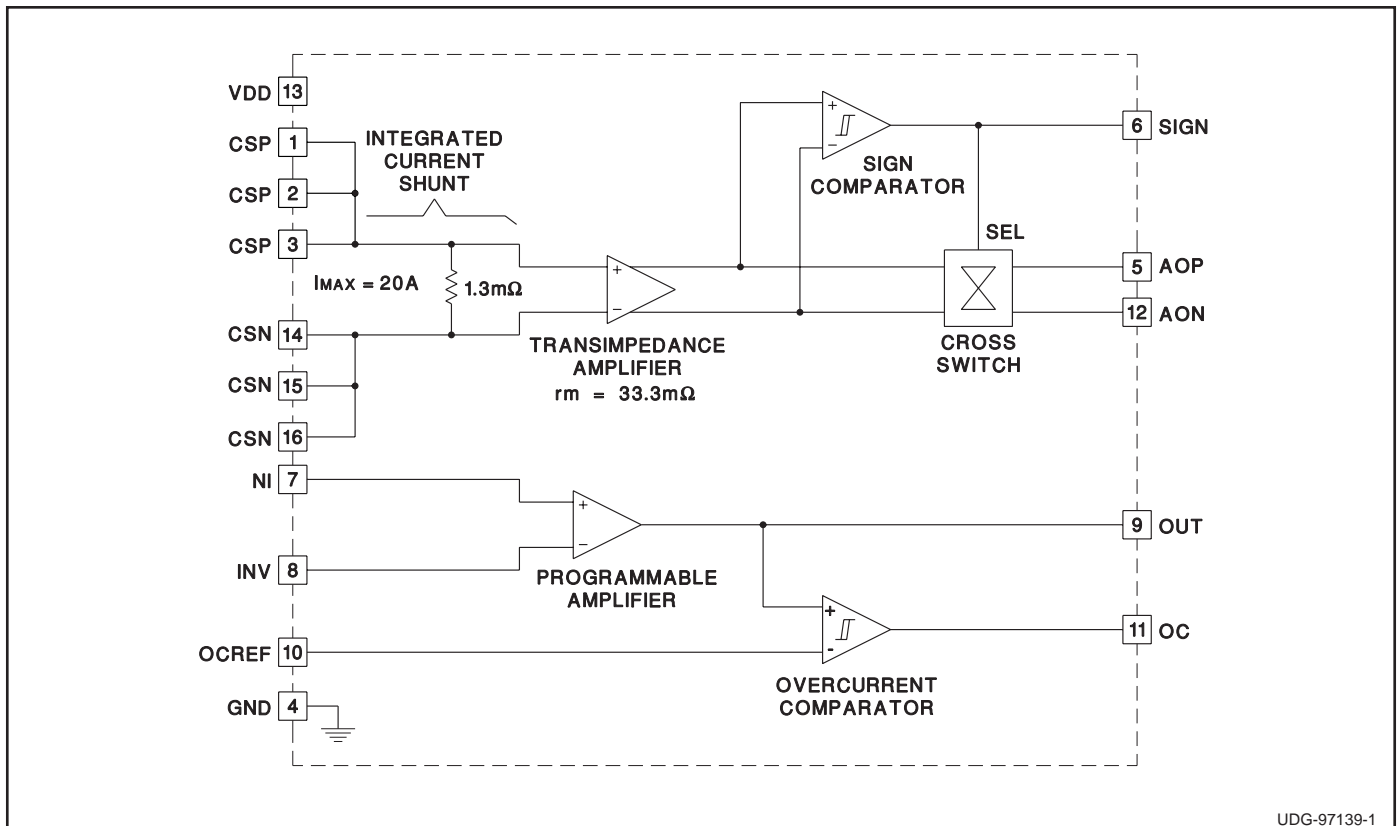

UDG-97139-1

## ABSOLUTE MAXIMUM RATINGS

Input Sense Current (I <sub>IN</sub> )	± 20A
Supply Voltage, V <sub>DD</sub>	14.5V
Inrush Current, 50μs	±100A
Input Voltage Range (CSP, CSN)	–0.2V to 14.5V
CSP, CSN, Common Mode Range (referenced to GND)	± 200mV
CSP, CSN, Common Mode Range (referenced to V <sub>DD</sub> )	± 200mV
Shunt Resistance	2.25mΩ
Storage Temperature	–65°C to 150°C
Junction Temperature	–55°C to 150°C
Lead Temperature (Soldering, 10sec.)	300°C

*Currents are positive into, negative out of the specified terminal. Consult Packaging Section of Databook for thermal limitations and considerations of packages.*

## TEMPERATURE & PACKAGE SELECTION GUIDE

	TEMPERATURE RANGE	AVAILABLE PACKAGES
UCC1926	– 55°C to +125°C	DS
UCC2926	– 40°C to +85°C	DS
UCC3926	0°C to +70°C	DS

## CONNECTION DIAGRAM

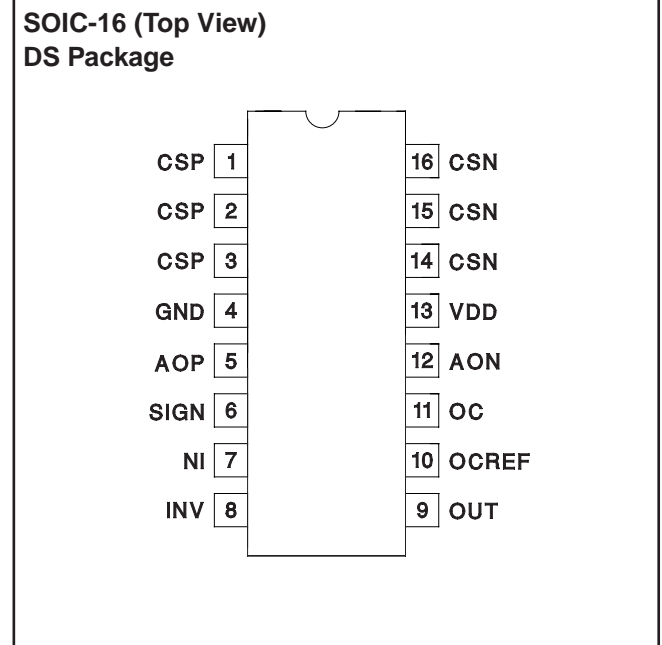

**ELECTRICAL CHARACTERISTICS:** Unless otherwise stated, these specifications apply for V<sub>DD</sub> = 4.8V; all temperature ranges and T<sub>A</sub> = T<sub>J</sub>.

PARAMETER	TEST CONDITIONS	MIN	TYP	MAX	UNIT
<b>Supply</b>					
V <sub>DD</sub>		4.8		14	V
I <sub>VDD</sub>			3.8	6	mA
<b>Transimpedance Amplifier</b>					
AOP – AON	I <sub>IN</sub> = 15A, V <sub>DD</sub> = 10V, 25°C	490	500	510	mV
	I <sub>IN</sub> = 15A, V <sub>DD</sub> = 10V, 0°C to +70°C	485	500	515	mV
	I <sub>IN</sub> = 15A, V <sub>DD</sub> = 10V, –40°C to +85°C	475	500	525	mV
	I <sub>IN</sub> = 15A, V <sub>DD</sub> = 10V, –55°C to +125°C	470	500	530	mV
Quiescent Output Voltage (AOP, AON)	I <sub>IN</sub> = 0		1.0		V
Quiescent Differential Voltage (AOP – AON)	I <sub>IN</sub> = 0, Measure AC Peak to Peak		0	15	mV
Bandwidth	(Note 1)	20	40		MHz
Output Impedance			350	500	Ω
Shunt Resistance	CSP to CSN		1.3		mΩ
PSRR	V <sub>DD</sub> = 4.8V to 10V	45			dB
	V <sub>DD</sub> = 10V to 14V	25			dB
Temperature Coefficient	(Note 1)	–200		200	ppm/°C
<b>Sign Comparator</b>					
V <sub>OH</sub> , V <sub>DD</sub> – SIGN	CSP = 1A, I <sub>SIGN</sub> = –100μA, CSN = 0V		0.2	0.4	V
V <sub>OL</sub> , SIGN	CSP = –1A, I <sub>SIGN</sub> = 100μA, CSN = 0V		0.2	0.4	V
I <sub>IH</sub> Threshold	Ramp CSP, CSN = 0V		400	600	mA
I <sub>IL</sub> Threshold	Ramp CSP, CSN = 0V		–400	–600	mA
<b>Programmable Amplifier</b>					
A <sub>VOL</sub>		60	70		dB
GBW	At 200kHz	6	13		MHz
V <sub>IO</sub> (Trimmed)	V <sub>IN</sub> = 0.5V, 1.5V, 2.5V	–5		5	mV
PSRR	V <sub>DD</sub> = 4.8V to 10V	60			dB
	V <sub>DD</sub> = 10V to 14V	60			dB
Common Mode Input Range		0.5		2.5	V
I <sub>IB</sub> , Input Bias Current (NI, INV)			–100	–200	nA

**ELECTRICAL CHARACTERISTICS:** Unless otherwise stated, these specifications apply for  $V_{DD} = 4.8V$ ; all temperature ranges and  $T_A = T_J$ .

PARAMETER	TEST CONDITIONS	MIN	TYP	MAX	UNIT S
I <sub>IO</sub> , Input Offset Current			20	100	nA
V <sub>OL</sub>	INV – NI = 20mV, IO = 0μA		100	200	mV
	INV – NI = 20mV, IO = 200μA		150	300	mV
V <sub>OH</sub>	NI – INV = 20mV, IO = –200μA, (V <sub>DD</sub> – OUT)		1.2	2	V
V <sub>OH</sub> , Clamp	NI – INV = 20mV, V <sub>DD</sub> = 14V	6	7	8	V
I <sub>OL</sub>	OUT = 1.5V	1	3.5		mA
I <sub>OH</sub>	OUT = 1.5V	– 250	– 325		mA
<b>Overcurrent Comparator</b>					
OC Comp Threshold	OCREF = 2V	2.00		2.05	V
Common Mode Range	(Note 1)	0.1		V <sub>DD</sub> –2	V
Hysteresis		20	40	60	mV
V <sub>OL</sub>	(OCREF – OUT) = 100mV, IOC = 100μA		0.2	0.4	V
V <sub>OH</sub> , V <sub>DD</sub> - OC	(OUT – OCREF) = 100mV, IOC = –100μA		0.2	0.4	V
Propagation Delay	(OUT – OCREF) = ± 100mV		90	150	ns

Note 1: Guaranteed by design. Not 100% tested in production.

## PIN DESCRIPTIONS

**AOP:** Positive output of the converted current signal. Voltage from AOP to AON is the absolute value of the transimpedance amplifier output. AOP may show some “chopping” noise. The differential to single-ended conversion removes the common-mode noise between AOP and AON. Some high frequency filtering of AOP to GND can reduce the fast transient spikes. The output stage of AOP is shown in Figure 1.

**AON:** Negative output of the converted current signal. Voltage from AOP to AON is the absolute value of the transimpedance amplifier output. AON may show some “chopping” noise. The differential to single-ended conversion removes the common-mode noise between AOP and AON. Some high frequency filtering of AON to GND can reduce the fast transient spikes. Note that

AON is above GND voltage. The output stage of AON is shown in Figure 1.

**CSN:** Input connection to one end of the internal current sense shunt resistor. Nominal resistance from CSP to CSN is 1.3mΩ. The current shunt has a nominal temperature coefficient of 3530 ppm/°C. The temperature adjusted autozero gain is designed to cancel this temp co. effect. CSN may be referenced to GND for low side sensing or to V<sub>DD</sub> for high side sensing. CSP – CSN may vary from ±75mV from either GND or V<sub>DD</sub>. Current into CSN is defined as negative.

**CSP:** Input connection to the other end of the internal current sense shunt resistor. Nominal resistance from CSP to CSN is 1.3mΩ. The current shunt has a nominal temperature coefficient of 3530 ppm/°C. The temperature adjusted autozero gain should cancel this temp co. effect. CSP may be referenced to GND for low side sensing or to V<sub>DD</sub> for high side sensing. CSP – CSN may vary from ±75mV from either GND or V<sub>DD</sub>. Current into CSP is defined as positive.

**GND:** This pin is the return point for all device currents.

**INV:** Negative input to the programmable amplifier to provide differential to single-ended signal conversion.

**NI:** Positive input to the programmable amplifier to provide differential to single-ended signal conversion.

**OC:** Overcurrent comparator output. When OUT is greater than OCREF, OC switches high. The OC comparator has a typical hysteresis of 25mV.

**OCREF:** The reference pin of overcurrent comparator for setting overcurrent threshold voltage.

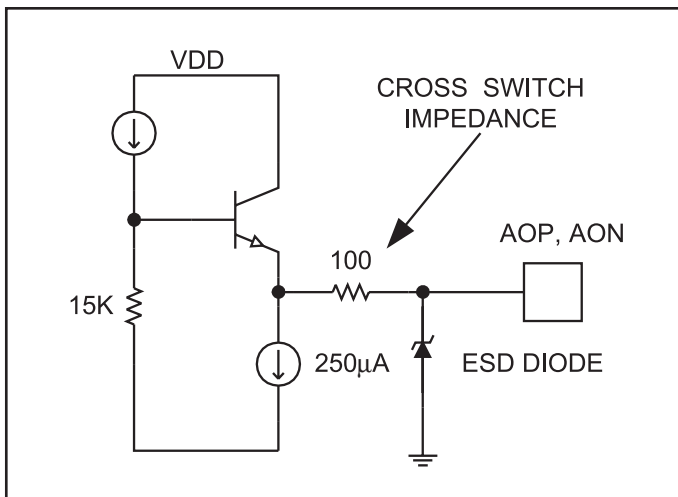

Figure 1. AOP and AON Output Stage

**OUT:** Output of the programmable amplifier intended to provide differential to single-ended signal conversion of the transimpedance amplifier's outputs.

Use this opamp to establish overall gain and nominal zero current reference voltage. This amplifier may be configured with a gain of one or more. Any non-common mode "chopping" noise between AOP and AON will show up at OUT. Some filtering of OUT may improve the application's performance.

**SIGN:** Sign comparator output. SIGN also controls the analog switches in the cross-switching block to keep AOP greater than AON. At currents near zero amps, the sign comparator may switch from "chopping" noise from the transimpedance amplifier.

**VDD:** VDD is the power input connection for this device. Its input range is from 4.8V to 14V. Bypass to GND using good quality ceramic capacitors.

**TYPICAL CHARACTERISTICS CURVES**

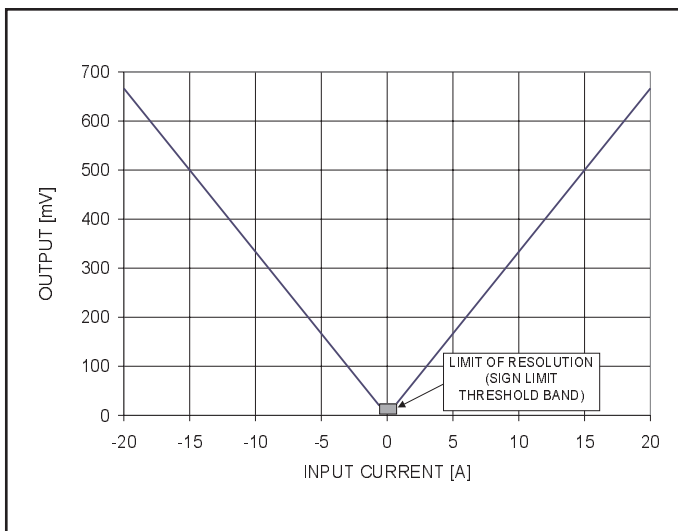

**Figure 2. Differential Output Voltage (AOP-AON) vs. Input Current (I<sub>IN</sub>)**

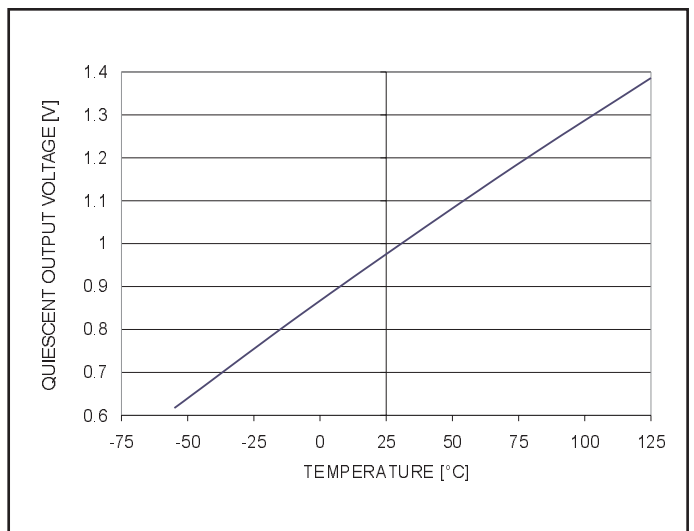

**Figure 3. Quiescent AOP, AON Output Voltage vs. Temperature**

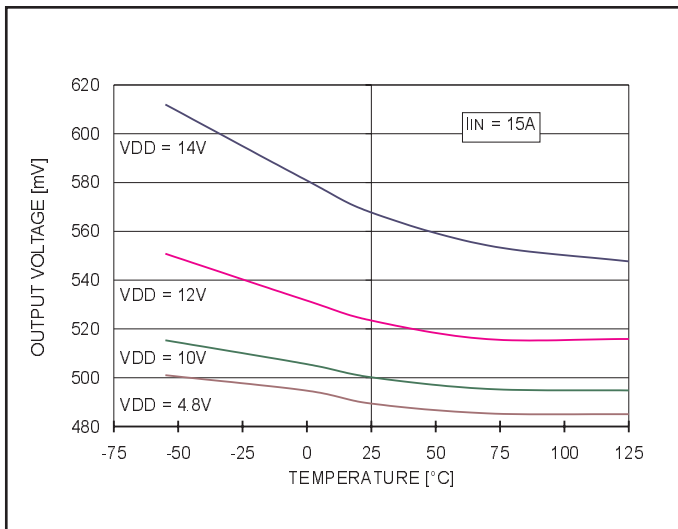

**Figure 4. Differential Output Voltage (AOP - AON) vs. VDD and Temperature**

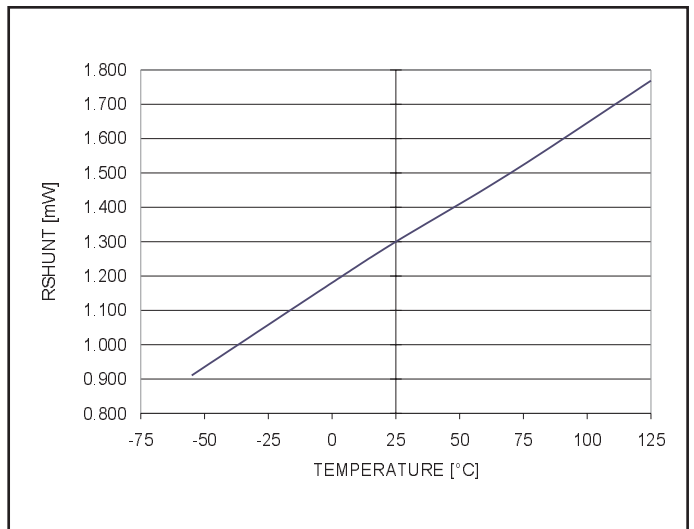
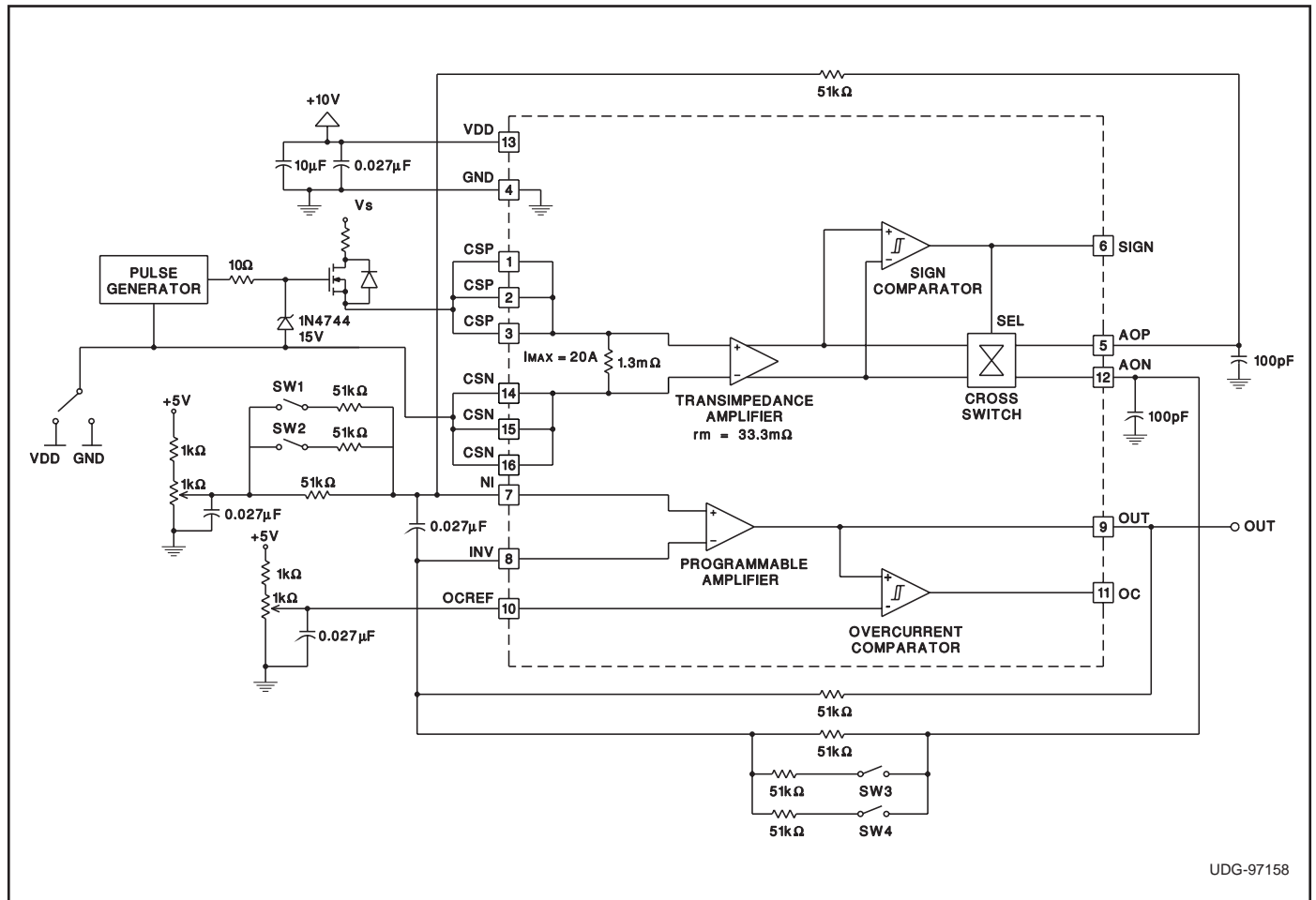

**Figure 5. Typical Shunt Resistance vs. Temperature**

### LAB EVALUATION CIRCUIT

The circuit shown uses a pulse generator to switch currents while observing the analog voltage of the sensed current. A four position switch can be used to experiment

with different gain settings for the programmable amplifier. The OCREF voltage and the NI DC bias voltage can be adjusted with 1kΩ potentiometers to offset the amplifier output and set the overcurrent comparator threshold.



UDG-97158